

(STUDIO MAIN FLOOR)

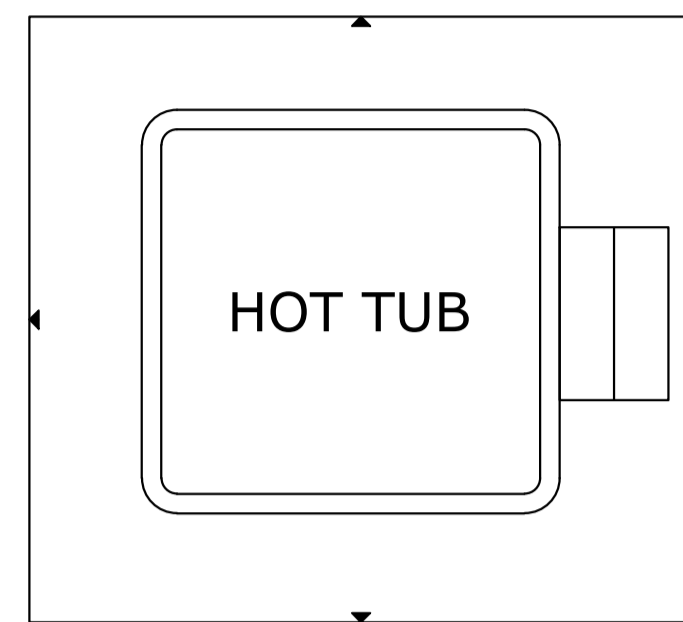

DECK
21'6" x 10'2"

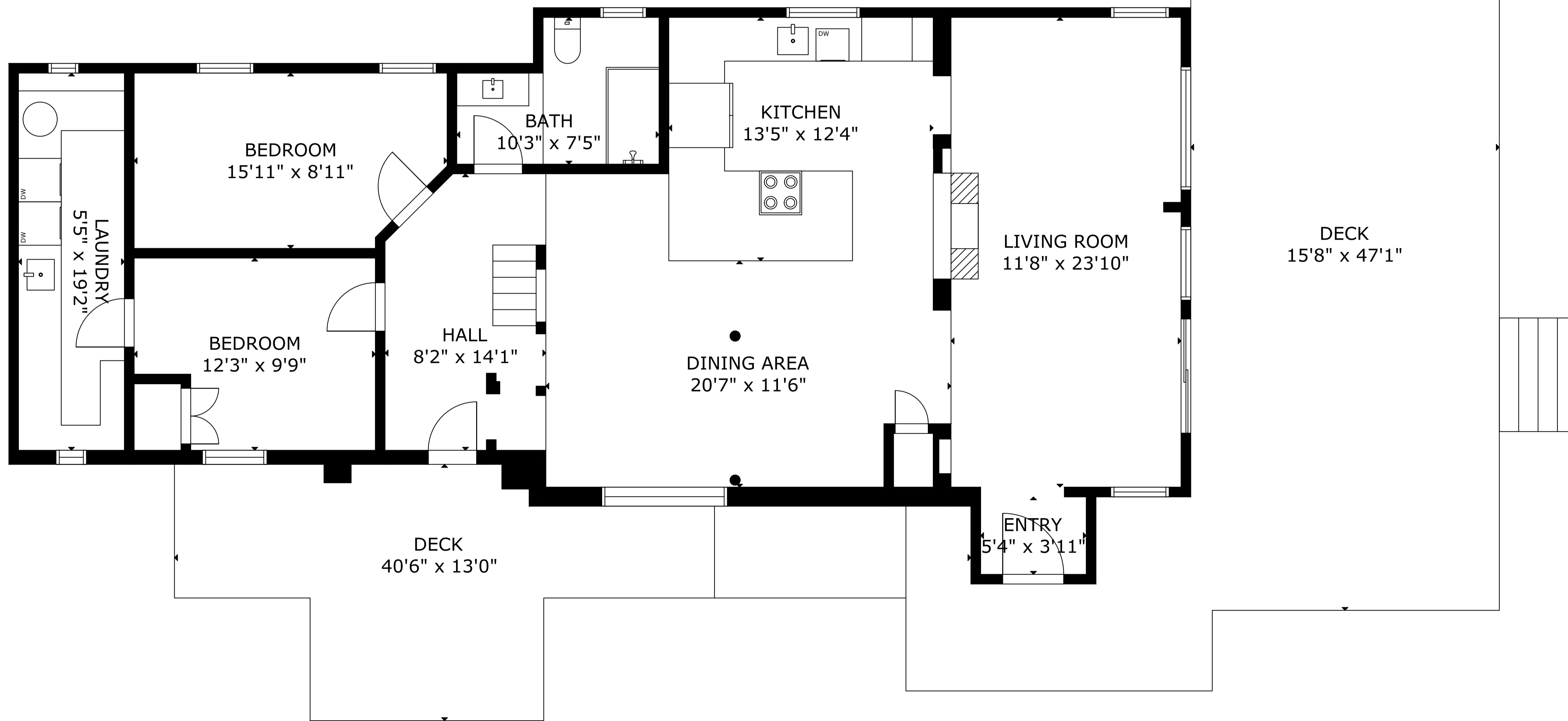
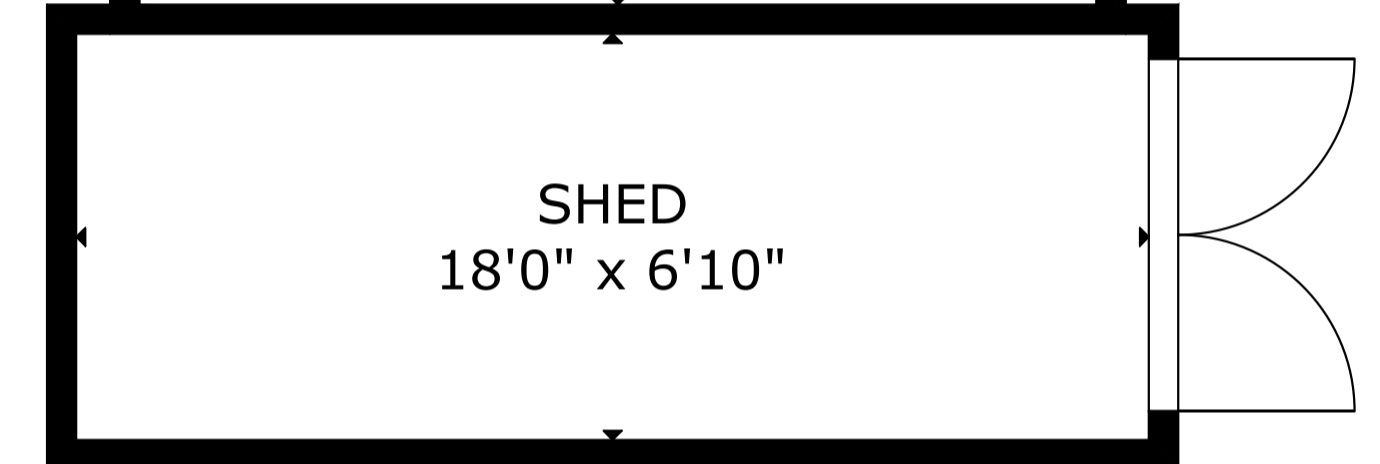
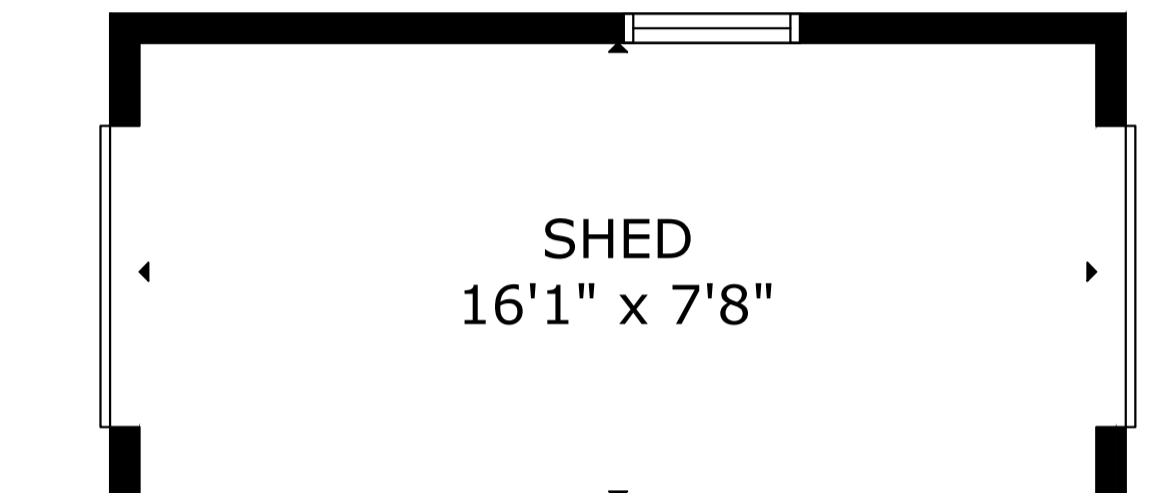
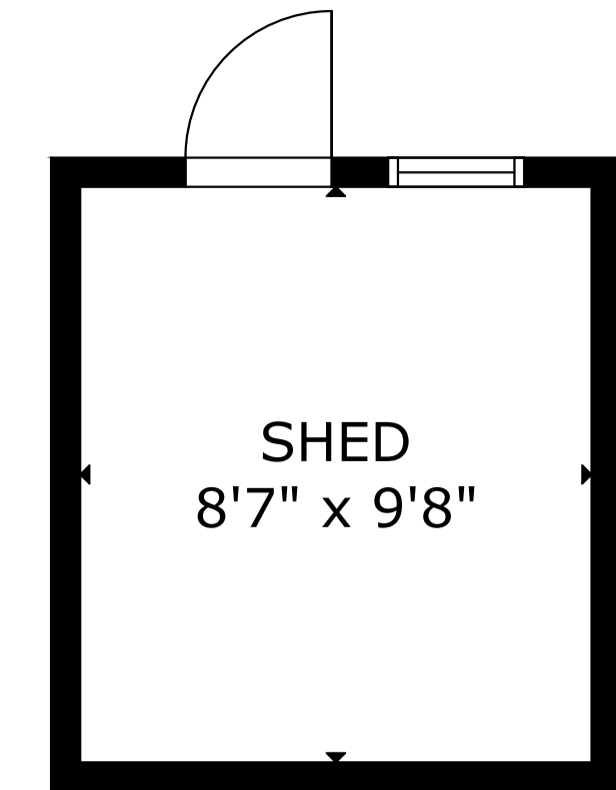
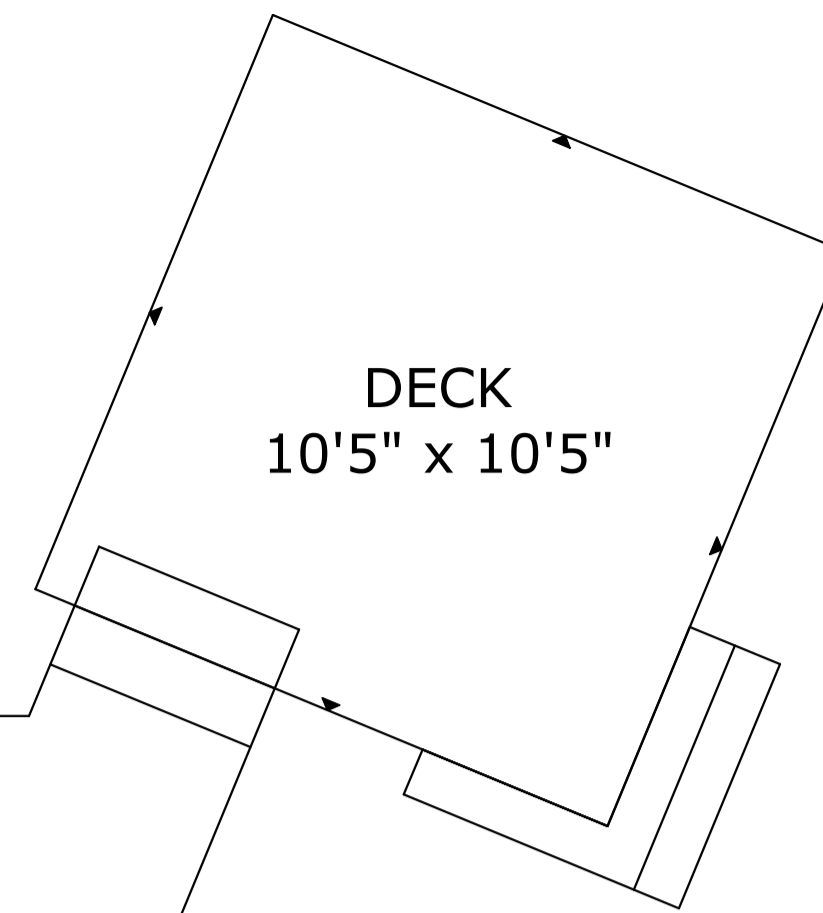

GROSS EXTERNAL AREA
TOTAL: 1,966 sq ft

MAIN FLOOR: 1,396 sq ft, UPSTAIRS: 570 sq ft

EXCLUDED AREAS: DECK: 1,627 sq ft, BALCONY: 70 sq ft, SHED: 338 sq ft

STUDIO MAIN FLOOR: 319 sq ft, STUDIO UPSTAIRS: 177 sq ft

SIZE AND DIMENSIONS ARE APPROXIMATE, ACTUAL MAY VARY